



www.verticalxpress.com

vertical express

Door Restrictors

Evacuation Deterrents

Passengers who become trapped in elevators may try to self-evacuate by opening the car doors between landings, putting themselves at risk of serious injury or death. In an effort to reduce this risk, national codes require evacuation deterrent devices on elevators.

It is important that trapped passengers remain in the elevator until trained personnel arrive or until power is restored to the system and the car resumes normal operation. Door Restrictors, which prevent elevator car doors from being opened if the elevator is outside the unlocking zone, ensure that doors remain closed until appropriate action can be taken.

Vertical Express offers two options of Door Restrictors from which to choose:

- The Restrictor Clutch is mounted to the car door with a simple linkage arrangement. It is mechanical, so it does not need batteries, and it can be used on all new equipment or retrofit installations.
- A Hoistway Door Restrictor Kit is mounted directly to the car door, with two vanes mounted at each floor. This arrangement is ideal for low-rise applications and once installed, is virtually maintenance-free.

The installation of Door Restrictors improves passenger safety, meets national code and is a sound investment in your building's future. To determine which Door Restrictor configuration best fits your application, contact your local Vertical Express representative or call (866) 448-3789 toll free.

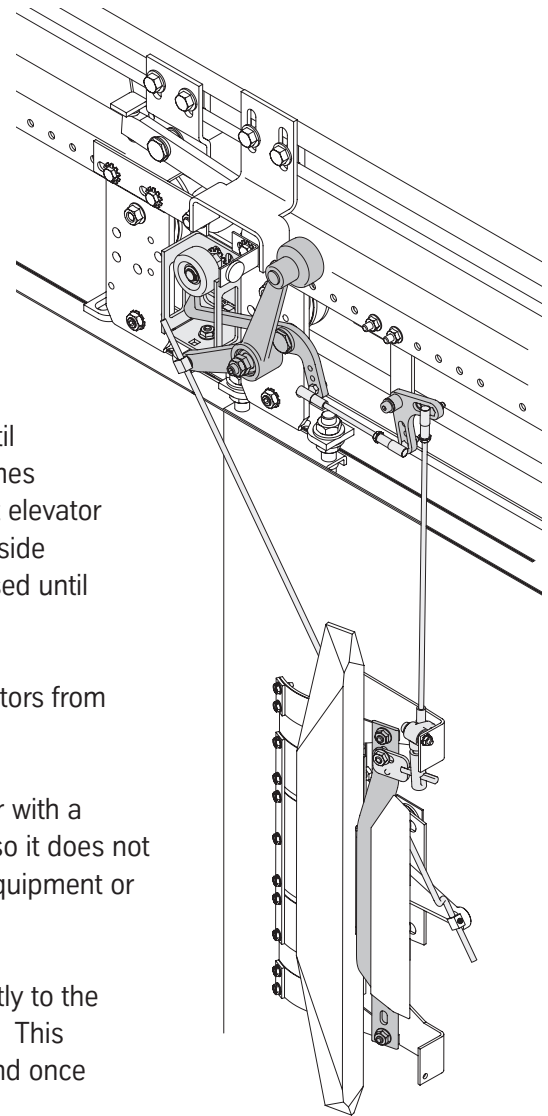

(866) 448-3789

expert service • express delivery

Vertical Express

P.O. Box 2019 Memphis, TN 38101 Tel: (866) 448-3789 (toll-free) Fax: (901) 261-1807 www.verticalxpress.com
All illustrations and specifications are based on information in effect at the time of publication approval. Vertical Express reserves the right to change specification or designs and to discontinue items without prior notification or obligation. v.06.08. Copyright © 2008 Vertical Express